

Sensing Kirigami

Clement Zheng

ATLAS Institute
University of Colorado, Boulder
clement.zheng@colorado.edu

Hyunjoo Oh

School of Industrial Design &
School of Interactive Computing
Georgia Institute of Technology
hyunjoo.oh@gatech.edu

Laura Devendorf

ATLAS Institute &
Department of Information Science
University of Colorado, Boulder
laura.devendorf@colorado.edu

Ellen Yi-Luen Do

ATLAS Institute
University of Colorado, Boulder &
Keio-NUS CUTE Center
National University of Singapore
ellen.do@colorado.edu

ABSTRACT

This pictorial presents our material-driven inquiry into carbon-coated paper and kirigami structures. We investigated two variations of this paper and their affordances for tangible interaction; particularly their electrical, haptic, and visual aspects when shaped into three-dimensional forms through cutting, folding, and bending. Through this exploration, we uncovered distinct affordances between the two paper types for sensing folds and bends, due to differences in their material compositions. From these insights, we propose three applications that showcase the possibilities of this material for tangible interaction design. In addition, we leverage the pictorial format to expose working design schematics for others to take up their own explorations.

Permission to make digital or hard copies of all or part of this work for personal or classroom use is granted without fee provided that copies are not made or distributed for profit or commercial advantage and that copies bear this notice and the full citation on the first page. Copyrights for components of this work owned by others than ACM must be honored. Abstracting with credit is permitted. To copy otherwise, or republish, to post on servers or to redistribute to lists, requires prior specific permission and/or a fee. Request permissions from Permissions@acm.org.

DIS '19, June 23–28, 2019, San Diego, CA, USA
© 2019 Association for Computing Machinery.
ACM ISBN 978-1-4503-5850-7/19/06...\$15.00
<https://doi.org/10.1145/3322276.3323689>

INTRODUCTION

Paper is a modest material with rich affordances for craft and design. Paper comes in many different compositions. It can be shaped into delicate objects that move with the slightest touch; or constructed into robust structures that support a building [1]. As HCI designers and researchers, we are attracted to the qualities of paper for facilitating tangible interactions. We are particularly curious about *kirigami* (切り紙): a Japanese term we borrow to describe cutting, folding and bending flat sheets of paper into three-dimensional forms. Kirigami enables us to shape paper into pliable structures that move dynamically to afford tangible interactions. Our material-driven exploration is anchored in carbon-coated paper—an electrically resistive material affected by folding and bending. We investigated two types of paper for sensing tangible interactions and harnessed insights gained from them to inform three design propositions—tangible interfaces that range from part to product.

This pictorial describes our materials-led inquiry at the intersection of carbon-coated paper and kirigami structures. Our intention is to leverage the pictorial format to provide readers with an in-depth understanding of not only what we can make, but the underlying physics of coated papers that our designs leverage. Furthermore, we have preserved and embedded design schematics as fabrication-friendly vector graphics¹ to facilitate others taking up our designs. As such, our pictorial functions as both a way for us to document and share our process, while also a workbook-like format that invites others to take up their own explorations.



Exploring kirigami objects.

¹ The interactive kirigami design schematics can be accessed and edited by opening this PDF with an application like Adobe Illustrator.

RELATED WORK

Open electronics platforms like the Arduino ecosystem offer a wide range of components for physical sensing and actuation. So called *electronics as material* [2], they facilitate designers to embed computation into physical artifacts. On the other hand, we are drawn to the notion of *material as electronics*—harnessing the inherent properties of physical materials as resources for tangible interaction. We are inspired by the work done in *computational composites* [20] as well as *kit-of-no-parts* [12] and want to explore this in the context of paper.

Integrating paper and electronics

Electronics has been integrated with paper within HCI as a means to prototype interface ideas, or to harness the qualities of paper as a creative and interactive medium. *BOXES* for example, enables rapid prototyping of functional interfaces through cardboard, thumbtacks, and tinfoil [7]. Buechley and colleagues blended electronic components with paper craft techniques and painting in a computational sketchbook to demonstrate the aesthetics of paper computing [3]. Their work inspired subsequent research where interactive elements are constructed from paper itself (rather than off the shelf parts) [13,14], as well as *Chibitronics*, a company that offers materials and tools for paper-based electronics [24]. Paper-based electronics has also been explored with digital fabrication. Notably, *PEP* demonstrates a technique which employs inkjet circuit printing and paper-based additive manufacturing to fabricate functional three-dimensional objects with embedded sensing and actuation [11].

Sensing paper

Our pictorial focuses on sensing paper. Related work in this area can be broadly classified into touch sensing and deformation sensing. Shorter and colleagues explored screen printing with conductive paint to embed discrete touch and proximity sensors [17]. Furthermore, they provide guidelines on making these screen-printed circuits [18]. Other research demonstrated paper-based composites that can report touch location, by inkjet printing a 2D array of sensors [5], or through electrical tomography on carbon-coated paper [23]. Researchers have also demonstrated techniques to sense the deformation of paper, including folding, bending, and cutting. *Flexy* employs a meandering trace to sense flexing; the electrical resistance of this trace increases when under tension and decreases when compressed [19]. *FlexSense* employs an array of piezoelectric electrodes distributed around a sheet to approximate its deformation [15]. *ShapeMe* also demonstrates using an array of capacitive traces to sense cutting [22]. These techniques employ inkjet printing of conductive inks.

Actuating Paper

We are keen to explore actuating paper for future work. We are inspired by work on shape-changing interfaces that combine paper's resistance to physical deformation with shape memory materials [14,16,21]. We are also inspired by paper mechatronics as an economical and customizable approach to actuate paper objects [10].

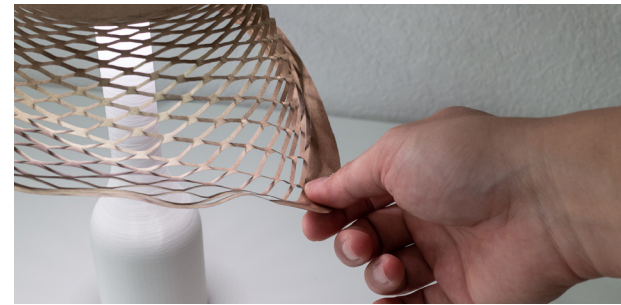

Sensing kirigami lamp shade



Sensing kirigami button

KIRIGAMI AFFORDANCES FOR TANGIBLE INTERACTION

Paper is ubiquitous and “present” [6]. Despite advancements in electronic information technology, people still jot ideas down on napkins and notebooks, read books, and archive important information on paper. We are attracted to the democratic and tangible qualities of this material and the range of engagements and aesthetics that it affords. We are particularly drawn to kirigami, which is used traditionally in Japan as a decorative technique and in similar forms across other cultures. Today, kirigami is applied creatively across diverse contexts, from the fine arts to nanoscale engineering; and even as a point of intersection between these different fields [4].

We extend the work on paper-based interfaces through exploring the affordances of kirigami for tangible interaction. Paper is easily worked through cutting, folding, and bending; yet, paper also resists these deformations depending on its material composition and weight. During our exploration, we investigated the range of haptic feedback delivered by different kirigami objects. Through different cutting and folding patterns, these objects multiply the material properties of paper to afford coherent interactions such as pushing, stretching and twisting.

We are also compelled by the dynamic visual nature of kirigami objects. Kirigami essentially transforms flat planes into three-dimensional sculptures, resulting in a visual texture that is aesthetically complex. Furthermore, this texture changes as the object is physically manipulated. We explored how these visual properties can be directed to signify different tangible interactions for HCI.



Cross section: SF Paper.



Cross section: PASCO Paper.

MATERIAL: CARBON-COATED PAPER

We were inspired by research on inkjet printed flex sensors [15,19], and much of our initial exploration was informed by this related work. However, inkjet printing is limited to substrates which are conducive to applying conductive ink; often synthetic polymers or composites with a synthetic coating. We were curious if such sensors could be embedded in a material that is more suitable to papercraft practices such as cutting, folding, bending, and gluing. We were also interested in exploring digital fabrication processes common to a makerspace, such as laser cutting or 2-axis plotting. To this end, we explored a variety of sheet materials with inherent conductive properties, including coating regular paper with conductive spray paint, and resistive polymers like Velostat.

Our investigations led us to carbon-coated paper (also known as resistance or teledeltos paper). This material is commonly used in physics classroom experiments to model different electrical phenomena. It consists of a sheet of organic paper with carbon fibers applied across its surface. It functions primarily as a two-dimensional resistor in these science experiments.

We selected two types of carbon-coated paper for our experiments based on local availability, supplied by companies *Science First* (SF) [25] and *PASCO* [26]. Besides their general physical differences, these two types of paper have significantly different carbon compositions. SF paper has carbon fibers mixed throughout its entire composition. As such, SF paper conducts electricity both across its surface and through the sheet. PASCO paper, on the other hand, is composed of a thin carbon coating on top of kraft paper. As such, PASCO paper conducts electrical current across its surface, but not through the sheet. This difference affects their ability to sense folding and bending. We elaborate on this in subsequent sections.

Resistance over length

We recorded the resistance across different lengths of SF and PASCO paper. Three 100mm by 30mm strips of paper were cut for each type of paper, and resistance was measured between two points with a digital multimeter. Based on these measurements, we observed that PASCO has a higher resistance over length than SF. Furthermore, we also observed that the increase in resistance is more inconsistent over length for PASCO compared to SF.

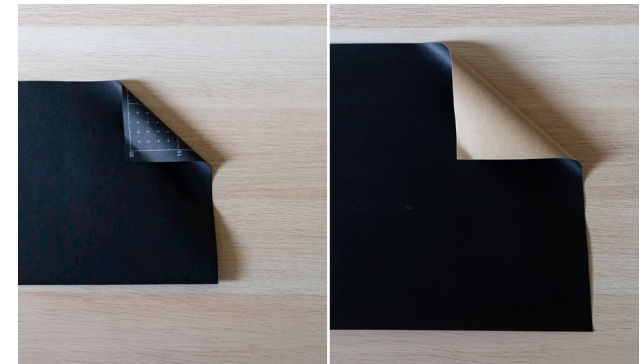

Science First

SIZE 278mm × 215mm
WEIGHT 100gsm

PASCO

SIZE 456mm × 303mm
WEIGHT 135gsm

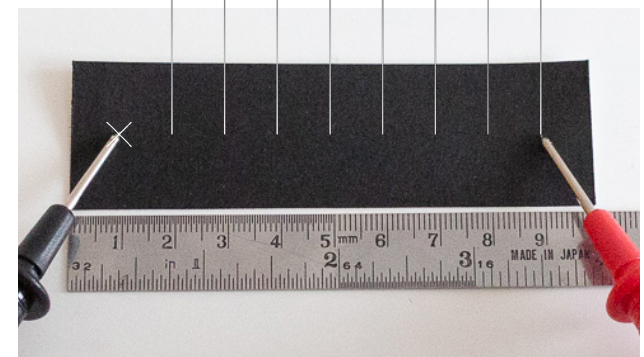
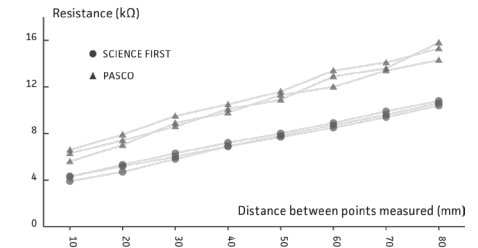

FOLDING TESTS

Folds are an integral building block for kirigami. We investigated the effect of folds on the electrical resistance of carbon-coated paper. This is informed by prior work on inkjet printed sensors [19]. For printed sensors, resistance decreases as a conductive trace is folded inwards due to the closer packing of conductive particles. The opposite happens as the trace is folded outwards. We tested this phenomenon for SF and PASCO paper. Three 60mm by 20mm strips were prepared for each material. A laser cut jig was constructed to hold strips at different fold angles, and the resistance of the strip was measured from end to end with a digital multimeter. Each strip was fatigued through multiple folding cycles prior to taking the readings. Two readings were taken at each angle for the strips and the results are visualized in the accompanying charts.

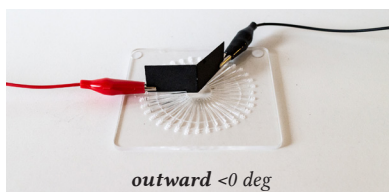
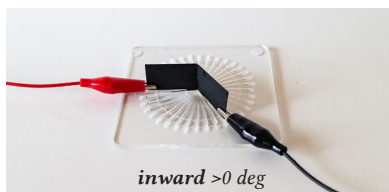
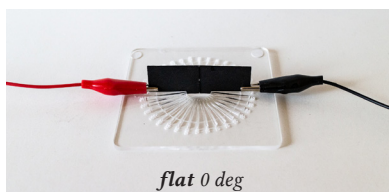

Experiment set-up: laser cut jig, alligator clip connections.

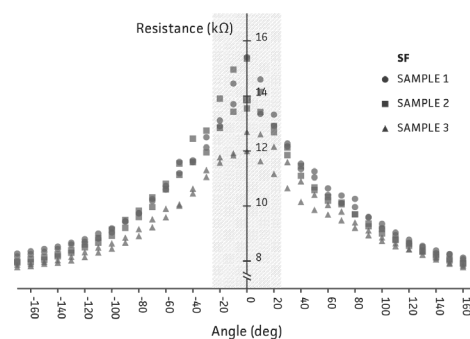

Folding SF Paper

Creasing the SF paper strip increased its resistance at 0 degrees (flat), from $\sim 9\text{k}\Omega$ to $\sim 14\text{k}\Omega$. Resistance decreases for SF paper as fold angle increases, regardless of fold direction. In fact, we observed that resistance change is almost mirrored for both inward and outward folding. However, we noticed that values are noisy between ± 20 degrees. Closer inspection of the material reveals a “ridge” on both faces of the strip along the fold as fibers bunch up. We hypothesize that as this ridge compresses with folding, the conductive fibers pack closer together, thus lowering the strip’s overall resistance.

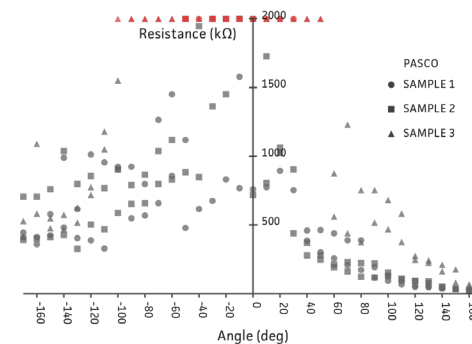

Folding PASCO Paper

The resistance of the PASCO paper strips increases significantly after creasing, from $\sim 13\text{k}\Omega$ to more than $700\text{k}\Omega$ (at 0 degrees folded). Resistance change was noisy and seemingly incoherent for PASCO paper regardless of fold angle. Large inward fold angles (>120 degrees) appear to be an exception, where this material exhibits similar characteristics to SF paper. Closer inspection reveals cracks that form along the crease, and these cracks are exacerbated as the material is fatigued through multiple folding cycles. This is also evident in the large range of resistance values recorded (spanning over $3\text{M}\Omega$).

Red marks in the chart indicate points where no resistance value could be read by the multimeter, likely due to a broken connection.

BENDING TESTS

Bends are another important kirigami building block. Like folds, we investigated bending's effect on the electrical resistance of carbon-coated paper. We were informed by commercial flex (bend) sensors [27], as well as prior work on inkjet printed sensors [19]. These sensors employ a resistive technique to measure bending. As a conductive trace is bent inward, the trace is compressed, compacting the conductive particles and decreasing overall resistance. As the same conductive trace is bent outward, the trace undergoes tension, separating the conductive particles and increasing overall resistance. We employed a similar procedure to the folding tests for bending. Three 60mm by 20mm strips were prepared for each material. In addition, SF paper strips were mounted on regular copy paper to create a composite with a conductive layer on one face of the strip and non-conductive layer on the other face. A jig was fabricated with the laser cutter to hold strips at different bending radius. The resistance of each strip was measured twice at each bending radii for both tension and compression.

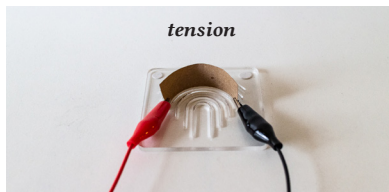
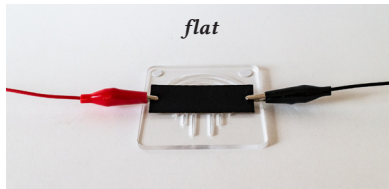

Experiment set-up: laser cut jig, alligator clip connections.

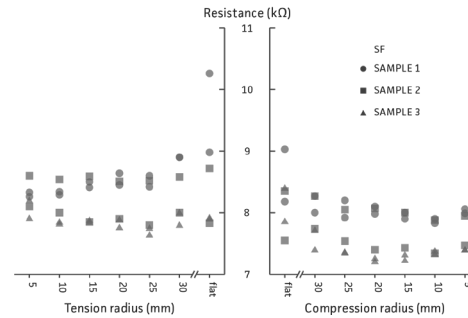

Bending SF paper

Resistance change for SF paper was mostly insignificant across different bending radii both during compression and tension. It appears that bending does not significantly affect electrical flow through the material, despite mounting this material on regular copy paper to create a strip with asymmetrical conductive properties across its two faces.

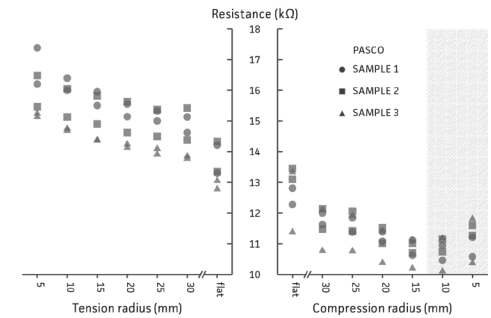

Bending PASCO paper

PASCO paper exhibits a similar resistive behavior to commercial and inkjet printed flex sensors. Resistance of the strips increase when bent under tension and decrease when bent under compression. We hypothesize that the carbon coating on PASCO paper is sufficiently thin for bending to change its resistance. A notable anomaly to this trend is the increase in resistance for compression at bend radii <10mm. We noticed crease lines form on the strip for such tight bends; these creases likely impede electrical current (see folding tests for PASCO paper).

AFFORDANCES FOR FOLDING AND BENDING

The material composition of SF and PASCO paper lead to distinct affordances for tangible interaction. SF paper consists of a uniform mesh of carbon and paper fibers. This paper thickens along a crease and is compressed when folded, thus lowering the overall resistance of the strip. PASCO paper consists of kraft paper with a thin coating of carbon. This coating cracks when creased and results in inconsistent resistive behavior during folding. However, the same thin carbon coating for PASCO paper enables it to perform better at sensing bends (compared to SF paper), due to the same phenomena exhibited by inkjet printed flex sensors. SF paper for folds, and PASCO paper for bends—with this simple heuristic in mind, we continued our exploration by investigating techniques for routing these sensing traces on top of kirigami patterns.

While folding and bending trends remain similar, it is important to note the variability in overall electrical resistance across different samples of the same material. When reading this material with a microcontroller it is important to calibrate each piece separately.

Etched trace: SF Paper mounted on 80gsm paper.

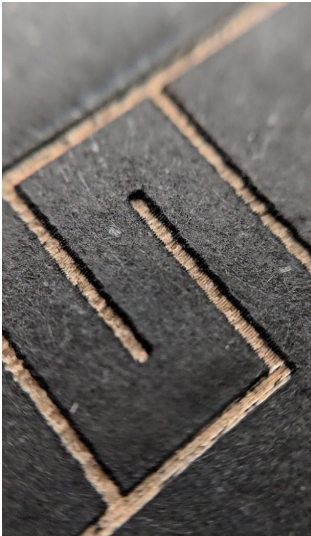

Etched trace: PASCO paper.

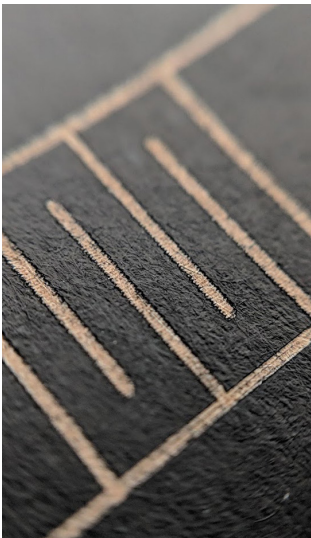

FABRICATION— TRACING CIRCUITS AND CUTTING PATTERNS

The resistive properties of carbon-coated paper can be applied to sense deformation in kirigami structures through their inherent folds and bends. In lieu of inkjet printing, we developed a subtractive fabrication process with laser cutting to overlay electrical traces on kirigami patterns; a technique similar to circuit milling. We employ these traces to guide electrical current through folds and bends—compounding their resistive properties for sensing tangible interactions.

1. SF paper is glue mounted onto a non-conductive sheet material before fabrication. This step can also be applied to PASCO paper to increase the material's weight.
2. The sheet is positioned and secured in the laser cutter.
3. The carbon layer is etched away via a raster operation to create electrical traces. Traces demarcated by cuts in the pattern do not require etching.
4. The kirigami pattern is then cut via a vector operation. Internal cuts are executed first, followed by cutting the outline.
5. Post laser cutting processes include folding, bending, and gluing part(s) into its three-dimensional structure.

These etched traces contribute graphically to the tangible interface. While we used rectilinear traces to complement the kirigami objects explored in this pictorial, these traces can take on many forms to fit the aesthetics of a paper interface. They are designed with a vector graphics tool like Inkscape or Illustrator.

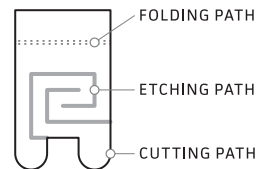

We use the following line types for all design schematics in this pictorial.

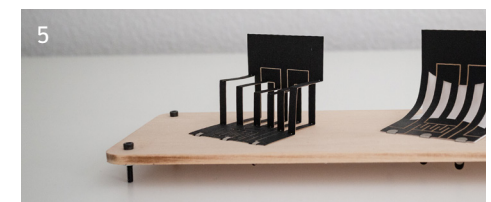
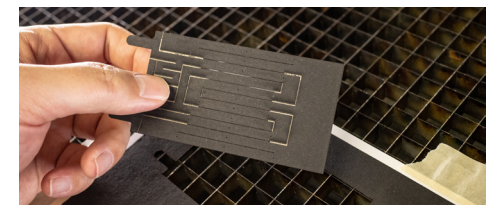
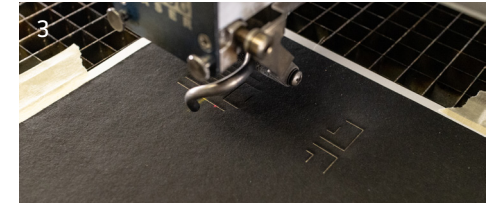
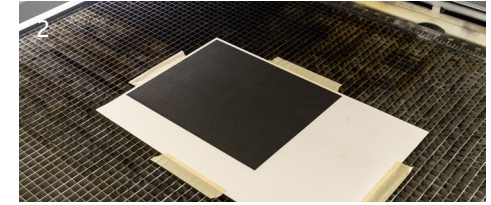
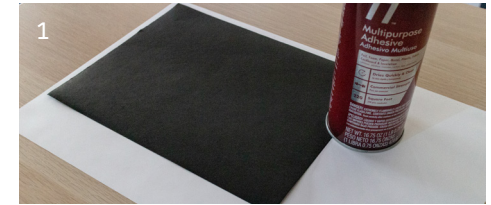

CONNECTIONS

Shorter and colleagues [18] identified connections as an integral component of paper-based tangible interfaces. While the fabrication process laid out in the earlier section demonstrates how to overlay electrical traces onto carbon-coated paper, connections often must be made to external hardware and components, such as microcontrollers and actuators. Furthermore, carbon is a resistive material—a poor conductor of electricity. For connections spanning a longer distance, it is inefficient to use traces etched into carbon-coated paper.

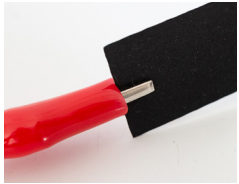

Alligator Clips

Alligator clips were primarily used during early stage prototyping. Microcontrollers such as the Micro:bit and Lilypad come with alligator clip friendly breakouts. Our own custom breakout incorporates this feature as well.

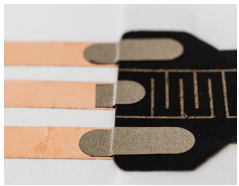

Conductive Fabric Patches

We found Chibitronics' conductive fabric patches ideal for bridging connections between carbon-coated paper and conductors like copper tape. They are convenient to apply and provide a highly conductive lead. The conductive adhesive used in these patches outperforms off-the-shelf copper tape.

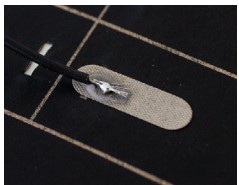

We were also able to solder directly onto these fabric patches with solder paste. Solder paste melts at a lower temperature compared to regular solder wire, thus avoiding damage to the fabric and paper underneath. We found such soldered connections structurally and electrically more robust than cold soldering techniques outlined in [18].

SENSING WITH VOLTAGE DIVIDERS

As with most resistive sensors, we used a voltage divider circuit to read kirigami interfaces fabricated from carbon-coated paper. We built a custom breakout board for *Adafruit's Trinket M0* [28] to facilitate our exploration. This microcontroller unit (MCU) provides four 12-bit analog inputs (a resolution of approximately 1mV per unit). Besides alligator clip connections, this breakout offers built-in voltage divider circuits—constant resistors are held in place with magnets and can be easily swapped to test different samples.

We also experimented with etching constant resistors into carbon-coated paper. This enables us to customize the constant resistor value so as to optimize the range sensor readings with a voltage divider. These inherent resistors also minimize external hardware involved when prototyping kirigami interfaces.

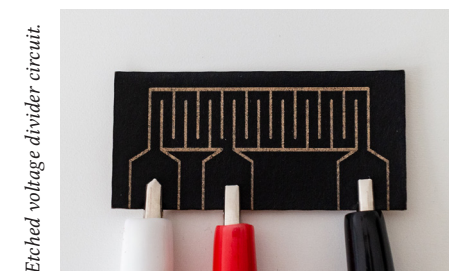
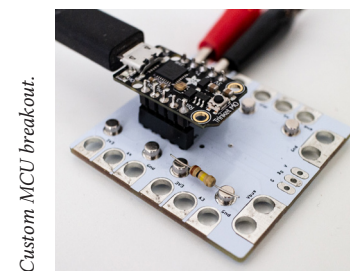
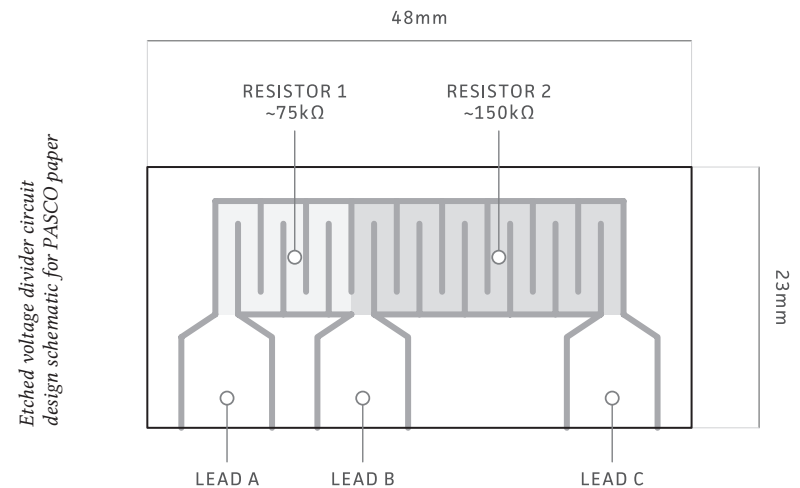

Fold sensor: SF paper.



Bend sensor: PASCO paper.

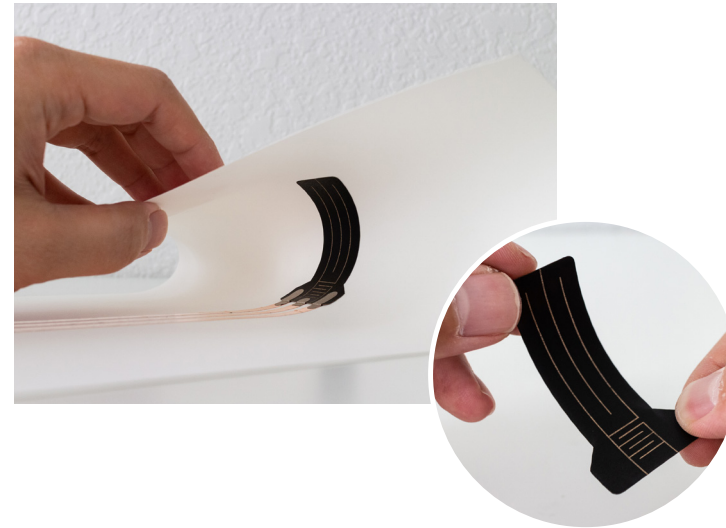

PROPOSITION I— FOLD AND BEND SENSOR PATCHES

These sensor patches encapsulate our insights from exploring the resistive properties and fabrication affordances of carbon-coated paper. Though these patches are not kirigami interfaces per se, they offer a minimal and economical method to sense folding and bending in other physical structures. They were designed to work well with paper circuit components such as copper tape and Chibitronics circuit stickers. While these DIY sensor patches work as is, designers and makers can also modify their schematics to customize sensor patches for different contexts and applications.

We fabricated the fold sensor patch from SF paper mounted onto regular copy paper, while the bend sensor patch is fabricated from PASCO paper. A meandering trace across the sensing regions compounds the resistive change due to folding and bending. An inherent voltage divider circuit is etched into these sensors. To read them, one simply connects power, ground, and data leads to the appropriate pins on a microcontroller. The accompanying charts report the microcontroller readings for these fold and bend sensor patches. Three samples were tested for each sensor, following a similar procedure to the fold and bend tests outlined in earlier sections of this pictorial.

Fold sensor schematic

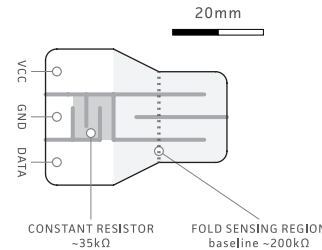

Fold sensor chart

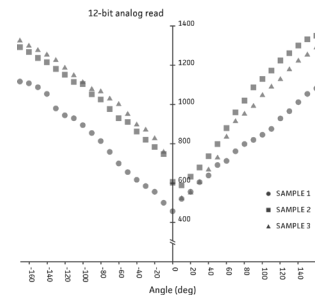

Bend sensor schematic

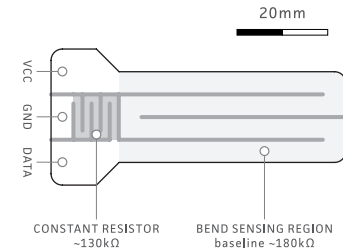

Bend sensor chart

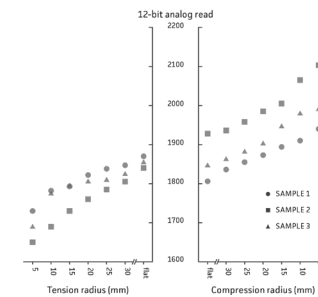

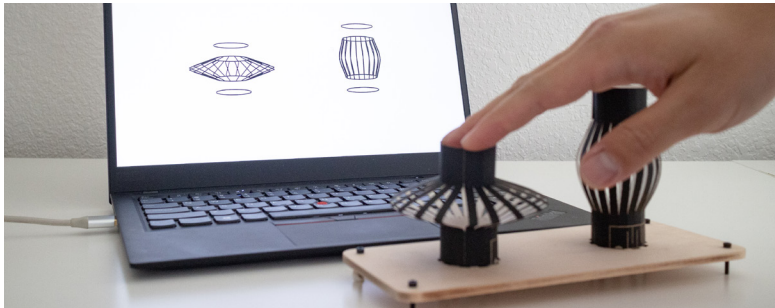

**PROPOSITION II—
KIRIGAMI INPUTS**

Paper resists physical deformation, and we explored harnessing this property for haptic interactions. We were particularly curious about how the distinct sensing affordances of SF and PASCO paper influence the haptic textures of kirigami interfaces they create. With this in mind, we propose a family of tangible inputs—a pair of buttons and hinges fabricated with SF paper and PASCO paper. These inputs are characterized by an array of slits, which multiplies the effect of folding and bending; compounding both the haptic feedback and resistive effect of these features for interaction. Voltage divider circuits were etched directly into the kirigami patterns. We developed a visualization to reflect the physical state of these four inputs.

The button and hinges offered a pleasant “spring” to physical interactions. Many of our colleagues who tried the kirigami inputs were surprised by the haptic feedback afforded by paper; one commented on the stark difference between pressing the “squishy” SF button compared to the “hard restitution” of the PASCO button. Indeed, we observed that bends provided more resistance than folds; more force is required to press the PASCO button, while the PASCO hinge sprung back into its rest position faster.



Button design schematic for SF paper.

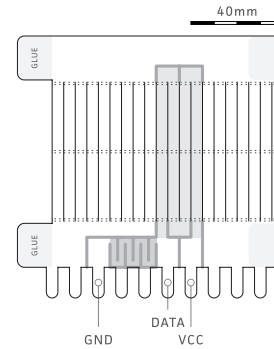

Button design schematic for PASCO paper.

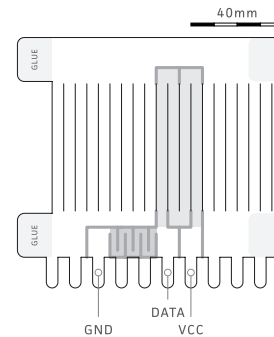

Hinge design schematic for SF paper.

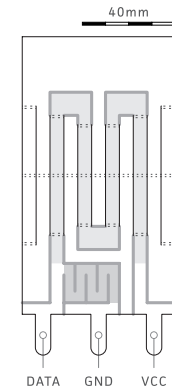

Hinge design schematic for PASCO paper.

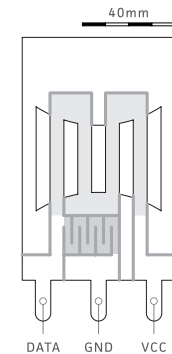

Button

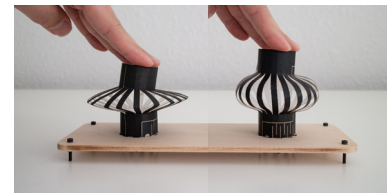

SF Paper

PASCO Paper

Hinge

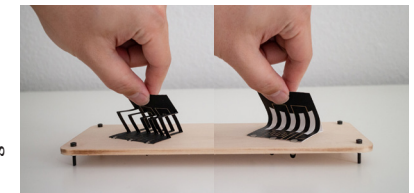

SF Paper

PASCO Paper

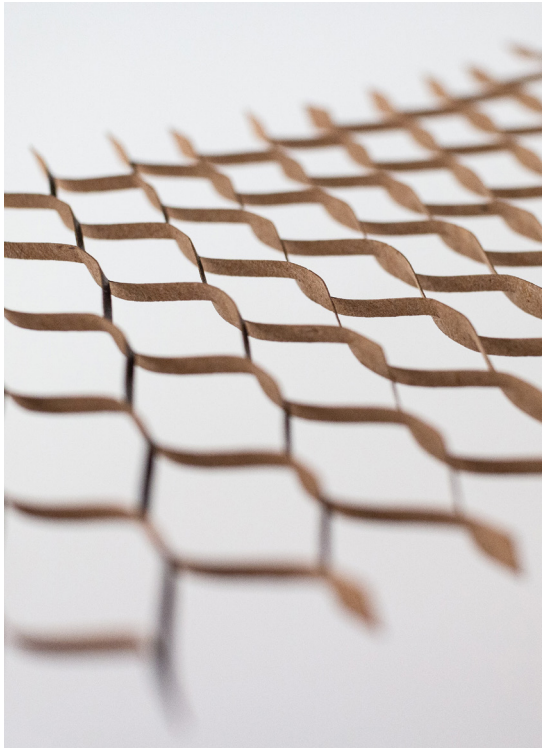

MULTIPLYING BENDS— FISHNET KIRIGAMI PATTERN

The fishnet kirigami pattern caught our attention during exploration. Many might recognize its humble application as padding for fragile packages. We were drawn to the rich visual and haptic qualities of this simple pattern—a series of alternating dashed cuts. When stretched, each row separates into waves that cascade down the paper’s surface; easily extending the structure to more than twice its original length. We also noticed that once stretched, the fishnet pattern establishes a certain “rest length”. This pattern offers resistance when pulled beyond this rest length and springs back when released. Design parameters such as the number of rows, height of each row, as well as frequency and size of the cuts, affect the visual and haptic qualities of this pattern.

Furthermore, the fishnet pattern can be seen as a dense series of bends—stretching the pattern decreases the radius of each bend. However, these bends occur both inward and outward, and we were curious if we could bias the pattern to affect its electrical resistance in one direction when stretched (either an overall increase or decrease). It turned out to be easier than anticipated. With PASCO paper, the fishnet patterns had a consistent increase in overall resistance when stretched. The accompanying chart illustrates the measurements taken for one such pattern (illustrated by the schematic).

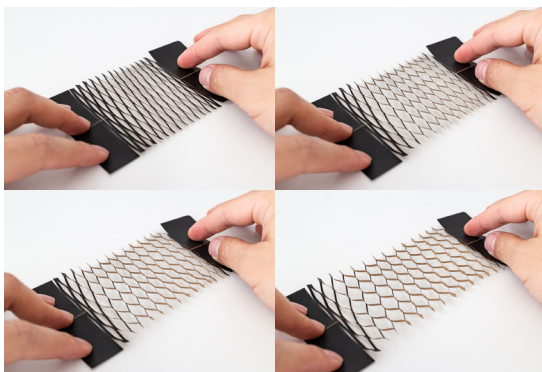

Stretching the fishnet pattern

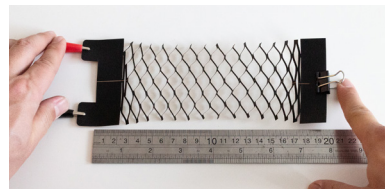
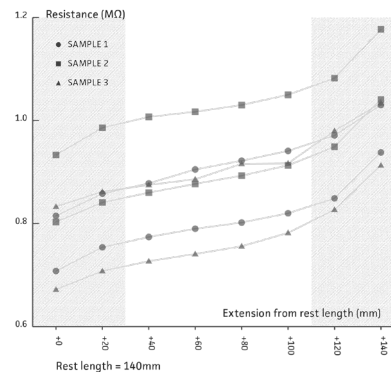

Experiment set-up

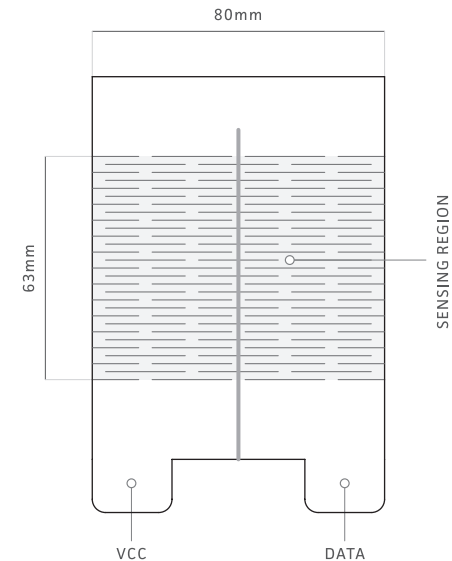

Schematic of fishnet pattern tested

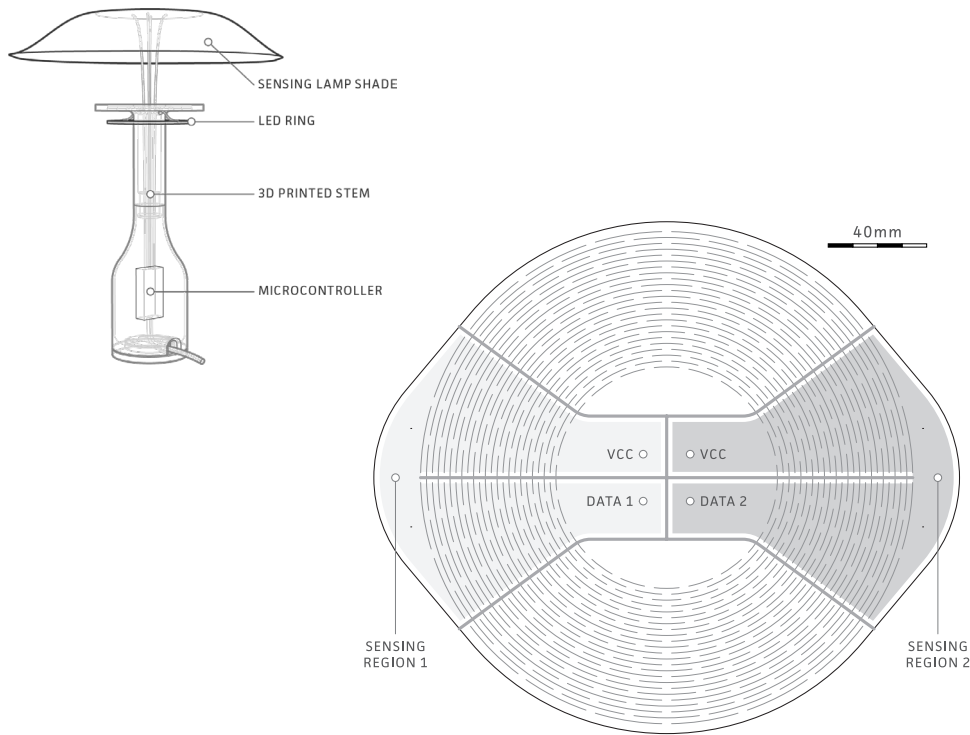

PROPOSITION III— HIRATAKE LAMP

We translated the visual and sensing affordances of fishnet kirigami patterns into a lamp with an interactive shade. The linear fishnet pattern in the previous section was modified to wrap in a radial manner. Two sensing regions were etched into this circular pattern, and handles were added along its perimeter to indicate points of interaction—pulling on one handle dims the light, while pulling the other brightens it. We exposed the natural texture of PASCO’s kraft paper backing to complement the organic three-dimensional form of the stretched lamp shade. Electrical leads in the center of the shade were connected to conductive fabric patches with soldered wires running down a 3D printed stem. The same stem houses a LED ring and microcontroller. We used off-the-shelf 330kΩ resistors to complete the voltage divider circuit for each sensing region in the lampshade.

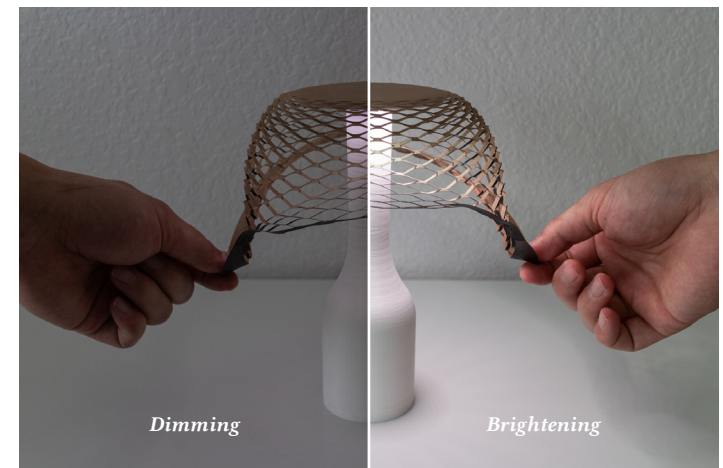

DISCUSSION

This pictorial describes our design exploration of carbon-coated paper and its affordances for tangible interaction. We discovered distinct resistive behaviors between two types of this material due to their different material compositions—something we took for granted at the start of our exploration. After all, both papers were manufactured with same purpose in mind for the science classroom. Their differences initially confounded us; and insights began to emerge through empirical testing and corroboration with related work. Through this process, we needed to create and adopt new tools and practices for experimenting and uncovering the computational affordances of this analog material. Our experience reminds us of the “untookit” in [9]. Mellis and colleagues described physical crafting as a process that emphasizes individual skill with tools, creative expression, and subtle variation; while conventional electronic toolkits emphasize standardization and “black-boxing” of technical details for the sake of usability. We leverage the properties of carbon-coated paper to create entire voltage divider circuits etched into kirigami objects. Through developing this technique, we developed a better understanding of electricity and voltage dividers; and the resultant etched traces also serve as a transparent way of documenting different circuit designs.

The carbon-coated paper we explored did not come with a datasheet. We knew that we were working with a resistive material, and with that in mind, we iteratively tested the papers’ electrical resistance with respect to kirigami features—eventually arriving at our heuristic for folding and bending. During exploration, we relied heavily on a digital multimeter (DMM) to take resistance measurements; but this device has its limitations. The LCD screen used by the DMM updates slowly at about four times a second, and each reading takes a few seconds to stabilize. Furthermore, we lose resolution at higher values as the DMM’s display is limited to three digits; some samples we experimented with had small changes in electrical resistance which could not be read with the DMM (e.g. $0.996\text{M}\Omega$ and $1.004\text{M}\Omega$ will both display as $1.00\text{M}\Omega$). To address these limitations, we developed a low-cost tool in the form of a breakout board with a customizable differential op-amp (LM358). We used a pair of trimpots in the tool for balancing the resistance of different samples, and another pair of trimpots to adjust the amount of amplification. This tool enabled us to amplify and digitally measure resistance changes, particularly for samples with a high overall resistance. We could also measure samples at a much higher frequency ($\sim 50\text{Hz}$) and smooth the measurements for greater accuracy. While the examples demonstrated in this pictorial did not require this tool, it was still

invaluable for “debugging” our material and kirigami samples during exploration. Using this tool required us to carefully turn the trimpots to catch the optimum resistance values for a sample. This process reminds us of the “tuning of materials” described by Karana and colleagues [8]; in our case, we were listening to the electrical, rather than emotional qualities, of the material.

We also investigated the material at different scales throughout our exploration. This was a significant new practice for us that led to many material insights. We employed an inexpensive macro lens that clips onto a phone’s camera for taking close-up images. This lens magnified and revealed hidden details that we would have missed by simply observing with our naked eye. Such details include the ridge that forms when creasing SF paper, or the cracks that appear for PASCO paper. We were also able to troubleshoot fabrication issues with this tool. For example, while iterating through different lampshade designs for the *Hiratake Lamp*, we encountered a sample with radically different electrical resistance measurements. Through the macro lens, we discovered that a gap between different sensing regions was etched incompletely. Tiny carbon traces were left behind, offering a path of lower resistance for electrical current to flow through. In addition, this practice of taking macro pictures served more than a practical function. Looking at the material at different scales heightened our sensitivity to its aesthetics. The differences in material composition between SF and PASCO paper were made obvious through close-ups of their cross-sections. The fibrous make-up of SF paper contributes to the neat ridges that form along its folds, while the distinct bilayer of PASCO results in a high visual contrast when etched. In addition, zooming in on the stretched fishnet revealed the intricate network of bends in this humble pattern—inspiring us to design a tangible interface around it.

There are certainly limitations to using carbon-coated paper for fold and bend sensing. As the charts illustrate, the electrical resistance of carbon coated paper varies significantly between material samples—the same design schematic yields different measurements for different samples when read with a DMM or microcontroller. Furthermore, fold and bend sensing can at times be erratic with this material; like at small fold angles for SF paper. In reflection, our exploration was as much about using *kirigami for sensing*, as it was about *sensing kirigami*. Through laser etching, we could route traces purposefully through kirigami patterns, compounding the effect of folds and bends. This enabled us to design and detect different tangible interactions—shaping coherent signals from a relatively noisy material.

Signal amplifier tool and schematic.

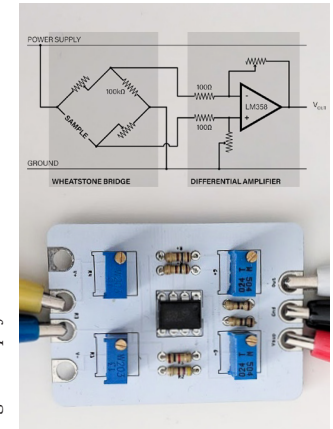

Close-up: Improperly etched carbon traces.

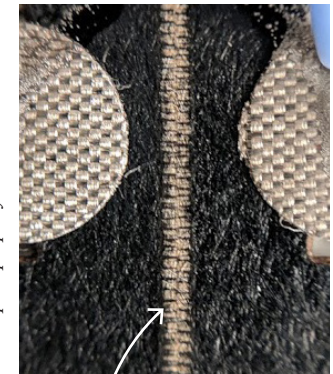

Big picture: Improperly etched carbon traces.

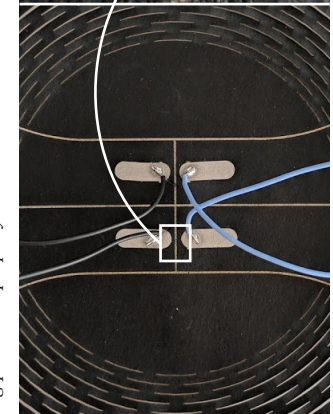

REFERENCES

- [1] Shigeru Ban, Riichi Miyake, Ian Luna, and Lauren A. Gould. 2009. *Shigeru Ban: paper in architecture*. Rizzoli International Publications, New York.
- [2] Ayah Bdeir. 2009. *Electronics As Material: LittleBits*. In Proceedings of the 3rd International Conference on Tangible and Embedded Interaction (TEI '09), 397–400. <https://doi.org/10.1145/1517664.1517743>
- [3] Leah Buechley, Sue Hendrix, and Mike Eisenberg. 2009. *Paints, Paper, and Programs: First Steps Toward the Computational Sketchbook*. In Proceedings of the 3rd International Conference on Tangible and Embedded Interaction (TEI '09), 9–12. <https://doi.org/10.1145/1517664.1517670>
- [4] Graham P. Collins. 2016. *Science and Culture: Kirigami and technology cut a fine figure, together*. Proceedings of the National Academy of Sciences 113, 2: 240–241. <https://doi.org/10.1073/pnas.1523311113>
- [5] Nan-Wei Gong, Jürgen Steimle, Simon Olberding, Steve Hodges, Nicholas Edward Gillian, Yoshihiro Kawahara, and Joseph A. Paradiso. 2014. *PrintSense: A Versatile Sensing Technique to Support Multimodal Flexible Surface Interaction*. In Proceedings of the 32Nd Annual ACM Conference on Human Factors in Computing Systems (CHI '14), 1407–1410. <https://doi.org/10.1145/2556288.2557173>
- [6] Lars Hallnäs and Johan Redström. 2002. *From Use to Presence: On the Expressions and Aesthetics of Everyday Computational Things*. ACM Trans. Comput.-Hum. Interact. 9, 2: 106–124. <https://doi.org/10.1145/513665.513668>
- [7] Scott E. Hudson and Jennifer Mankoff. 2006. *Rapid Construction of Functioning Physical Interfaces from Cardboard, Thumbtacks, Tin Foil and Masking Tape*. In Proceedings of the 19th Annual ACM Symposium on User Interface Software and Technology (UIST '06), 289–298. <https://doi.org/10.1145/1166253.1166299>
- [8] Elvin Karana, Elisa Giaccardi, Niels Stamhuis, and Jasper Goossensen. 2016. *The Tuning of Materials: A Designer's Journey*. In Proceedings of the 2016 ACM Conference on Designing Interactive Systems (DIS '16), 619–631. <https://doi.org/10.1145/2901790.2901909>
- [9] David A. Mellis, Sam Jacoby, Leah Buechley, Hannah Perner-Wilson, and Jie Qi. 2013. *Microcontrollers As Material: Crafting Circuits with Paper, Conductive Ink, Electronic Components, and an "Untoolkit"*. In Proceedings of the 7th International Conference on Tangible, Embedded and Embodied Interaction (TEI '13), 83–90. <https://doi.org/10.1145/2460625.2460638>
- [10] Hyunjoo Oh, Sherry Hsi, Michael Eisenberg, and Mark D. Gross. 2018. *Paper Mechatronics: Present and Future*. In Proceedings of the 17th ACM Conference on Interaction Design and Children (IDC '18), 389–395. <https://doi.org/10.1145/3202185.3202761>
- [11] Hyunjoo Oh, Tung D. Ta, Ryo Suzuki, Mark D. Gross, Yoshihiro Kawahara, and Lining Yao. 2018. *PEP (3D Printed Electronic Papercrafts): An Integrated Approach for 3D Sculpting Paper-Based Electronic Devices*. In Proceedings of the 2018 CHI Conference on Human Factors in Computing Systems (CHI '18), 441:1–441:12. <https://doi.org/10.1145/3173574.3174015>
- [12] Hannah Perner-Wilson, Leah Buechley, and Mika Satomi. 2011. *Handcrafting Textile Interfaces from a Kit-of-no-parts*. In Proceedings of the Fifth International Conference on Tangible, Embedded, and Embodied Interaction (TEI '11), 61–68. <https://doi.org/10.1145/1935701.1935715>
- [13] Jie Qi and Leah Buechley. 2010. *Electronic Popables: Exploring Paper-based Computing Through an Interactive Pop-up Book*. In Proceedings of the Fourth International Conference on Tangible, Embedded, and Embodied Interaction (TEI '10), 121–128. <https://doi.org/10.1145/1709886.1709909>
- [14] Jie Qi and Leah Buechley. 2012. *Animating Paper Using Shape Memory Alloys*. In Proceedings of the SIGCHI Conference on Human Factors in Computing Systems (CHI '12), 749–752. <https://doi.org/10.1145/2207676.2207783>
- [15] Christian Rendl, David Kim, Sean Fanello, Patrick Parzer, Christoph Rhemann, Jonathan Taylor, Martin Zirkl, Gregor Scheipl, Thomas Rothländer, Michael Haller, and Shahram Izadi. 2014. *FlexSense: A Transparent Self-sensing Deformable Surface*. In Proceedings of the 27th Annual ACM Symposium on User Interface Software and Technology (UIST '14), 129–138. <https://doi.org/10.1145/2642918.2647405>
- [16] Greg Saul, Cheng Xu, and Mark D. Gross. 2010. *Interactive Paper Devices: End-user Design & Fabrication*. In Proceedings of the Fourth International Conference on Tangible, Embedded, and Embodied Interaction (TEI '10), 205–212. <https://doi.org/10.1145/1709886.1709924>
- [17] Michael Shorter, Jon Rogers, and John McGhee. 2014. *Enhancing Everyday Paper Interactions with Paper Circuits*. In Proceedings of the 2014 Conference on Designing Interactive Systems (DIS '14), 39–42. <https://doi.org/10.1145/2598510.2598584>
- [18] Michael Shorter, Jon Rogers, and John McGhee. 2014. *Practical Notes on Paper Circuits*. In Proceedings of the 2014 Conference on Designing

- Interactive Systems (DIS '14), 483–492. <https://doi.org/10.1145/2598510.2602965>
- [19] Nirzaree Vadgama and Jürgen Steimle. 2017. Flexy: Shape-Customizable, Single-Layer, Inkjet Printable Patterns for 1D and 2D Flex Sensing. In Proceedings of the Eleventh International Conference on Tangible, Embedded, and Embodied Interaction (TEI '17), 153–162. <https://doi.org/10.1145/3024969.3024989>
- [20] Anna Vallgård and Johan Redström. 2007. Computational Composites. In Proceedings of the SIGCHI Conference on Human Factors in Computing Systems (CHI '07), 513–522. <https://doi.org/10.1145/1240624.1240706>
- [21] Guanyun Wang, Tingyu Cheng, Youngwook Do, Humphrey Yang, Ye Tao, Jianzhe Gu, Byoungkwon An, and Lining Yao. 2018. Printed Paper Actuator: A Low-cost Reversible Actuation and Sensing Method for Shape Changing Interfaces. In Proceedings of the 2018 CHI Conference on Human Factors in Computing Systems (CHI '18), 569:1–569:12. <https://doi.org/10.1145/3173574.3174143>
- [22] Michael Wessely, Theophanis Tsandilas, and Wendy E. Mackay. 2018. Shape-Aware Material: Interactive Fabrication with ShapeMe. In Proceedings of the 31st Annual ACM Symposium on User Interface Software and Technology (UIST '18), 127–139. <https://doi.org/10.1145/3242587.3242619>
- [23] Yang Zhang and Chris Harrison. 2018. Pulp Nonfiction: Low-Cost Touch Tracking for Paper. In Proceedings of the 2018 CHI Conference on Human Factors in Computing Systems, 117.
- [24] Welcome to Chibitronics. Retrieved January 14, 2019 from <https://chibitronics.com/>
- [25] Science First 24-1232 Conductive Paper (Pack of 25): Science Lab Education Curriculum Support: Amazon.com: Industrial & Scientific. Retrieved January 14, 2019 from <https://www.amazon.com/Science-First-24-1232-Conductive-Paper/dp/B00FGEI50M>
- [26] Conductive Paper (no Grid) - PK-9026: PASCO. Retrieved January 14, 2019 from https://www.pasco.com/prodCatalog/PK/PK-9026_conductive-paper-no-grid/index.cfm
- [27] Resistive Flex Sensors | Spectra Symbol Flex Sensors. Spectra Symbol - Innovation-Driven. Retrieved January 14, 2019 from <http://www.spectrasymbol.com/product/flex-sensors/>
- [28] Adafruit Trinket M0 - for use with CircuitPython & Arduino IDE ID: 3500 - \$8.95: Adafruit Industries, Unique & fun DIY electronics and kits. Retrieved January 14, 2019 from <https://www.adafruit.com/product/3500>